

Specification Sheet

C700 Positive Displacement Meter Polymer, Magnetic Drive, External Threaded Spuds



Size: 5/8" x 1/2", 5/8" x 3/4", 3/4" x 3/4" and 3/4" x 1"

Description

Operation. The C700 polymer meter is a positive displacement type meter operating on the oscillating piston principle. The product utilizes a piston that water use rotates in a measuring chamber, each piston revolution being equivalent to a known volume of water. The piston movement is transferred by magnetic drive to a straight reading sealed register which contains the appropriate reduction gearing.

Compliance to Standards/Approvals. The C700 polymer meter complies with all performance and material requirements of the American Water Works Association Standard C710 as most recently revised. The C700 polymer meter is NSF-61 Certified, complies with California Proposition 65 lead free requirements, and is California Department of Weights and Measures approved.

Installation. The meter must be installed in a clean pipe line, free from any foreign materials. Install the meter with direction of flow as indicated by the arrow molded in the meter case. The meter may be installed in horizontal or inclined lines.

Application. *The meter is for use in POTABLE COLD WATER up to 120°F (50°C) and working pressures up to 150 psi.* The meter will perform with accuracy registration of 100% ± 1½% within the normal flows. Both pressure loss and accuracy tests are made before shipment. No adjustments need to be made before installation.

Construction. The meter consists of a main case, an oscillating piston measuring chamber, a polymer strainer, a removable top plate and O-ring, and a magnetically driven register assembly. The main case is molded in plastic with raised characters showing model, size, and direction of flow. The measuring assembly is a top-in and a bottom-out design and consists of the measuring chamber with division plate, drive bar, magnet and a locator pin. The measuring chamber is held against its seat by the top plate. The threaded main case and top plate are assembled

Specifications

Sizes:	5/8" x 1/2"	5/8" x 3/4"	3/4" x 3/4" 3/4" x 1"
95% -101% Accuracy GPM	1/4	1/4	1/2
98.5%-101.5% Accuracy GPM	1-20	1-20	2-30
Continuous Flow GPM	15	15	15
Maximum Flow GPM	20	20	30
Operating Pressure psi	150	150	150
Operating Temperature °F	120*	120	120
	*(67°C)		
<u>Sweep Hand Registers:</u>			
US Gallons	10	10	10
Cubic Feet	1	1	1
Cubic Meters	1/10	1/10	1/10
Imperial Gallons	10	10	10
<u>Capacity of Register</u>			
US Gallons (millions)	10	10	10
Cubic Feet (millions)	1	1	1
Cubic Meters (millions)	1/10	1/10	1/10
Imperial Gallons (millions)	10	10	10
<u>Register Type</u>	Permanently sealed direct reading register		
<u>Materials</u>			
Main Case	Modified Acetal Copolymer		
Top Plate	Modified Acetal Copolymer		
Body O-ring	Neoprene Rubber		
Measuring Chamber	Compounded Thermoplastic		
Thrust Bearing Insert	Loaded Nylon		
Piston	High Impact Polymer		
Division Plate	Loaded Nylon		
Driving Bar	Loaded Nylon		
Strainer	Polypropylene		
Register Can	90% Copper Alloy		
Domed Register Lens	Tempered Glass		
Register Housing & Lid	Polymer		

with an O-ring gasket. Each register assembly is secured to the maincase with a tamperproof TORX® screw, is protected with a hinged lid and is positioned with its hinge over the inlet throat. However, the register can may be rotated and locked in any 360 degree position therein.

Connections. Meter casing spuds have external straight threads conforming to ANSI B2.1 Bronze or polymer coupling nuts and tailpieces are available. Both coupling nuts and tailpieces have external taper pipe threads conforming to ANSI B2.1 Their lengths and thread sizes are as specified by AWWA Standards.

Maintenance. The measuring chamber assembly can be removed, repaired or replaced without removing the main case from the service line. Pretested measuring chamber assemblies are available for exchange or purchase, and spare parts are available from our central warehouse or designated regional locations. AMCO Water Metering Systems staffs and operates a repair facility at its U.S. manufacturing plant in Ocala, Florida.

Register. The magnetically driven register is contained within a 90% copper seamless can which is oven-cured at 150°F for 90 minutes to eliminate condensation. The 1/4" true tempered glass lens is domed and secured in an "L" shaped gasket. To assure easy reading, the totalizer wheels are large and color coded. The applicable size, model, registration, part number and date code are printed on the calibrated dial face. Moving clockwise during operation, the extra thin center sweep hand does not interfere with meter reading and the 1:1 ratio low-flow indicator will give visual indication of plumbing leaks.



AMCO Water Metering Systems Inc.

www.amcowater.com

United States - ISO 9002 Registered
 AMCO Water Metering Systems
 P. O. Box 1852
 Ocala, FL 34478-1852
 352-732-4670 FAX 352-368-1950
 Outside Florida: 800-874-0890
 Inside Florida: 800-356-6829
 e-mail:
 watermeters@amcowater.com

Canada
 Elster Water
 3450 Harvester Road
 Burlington, Ontario L7N 3W5
 866-703-7582
 905-634-4895
 FAX 905-634-6705
 e-mail:
 watermeters@ca.elster.com

Reading Options. AMCO C700 meters are available with Generator, Absolute Encoder, Digital and InsideR™ (submetering) register options to provide water usage output to the entire spectrum of electronic meter reading systems, giving flexibility to utilities implementing or upgrading reading technologies. AMCO Encoder and Digital registers interface to a variety of automated meter reading systems, allowing technology upgrade without register replacement.

Remote Meter Reading (RMR). Generator-type remote meter reading systems have provided utilities with inside-set meters the ability to visually read meters without directly accessing the meter, greatly reducing reading cost and estimation rates. A 2-conductor wire carries register pulses, equal to a predetermined volume of water throughput, to a remote wall unit for accumulation and display.

Electronic Meter Reading (EMR). EMR permits electronic interrogation of the absolute encoder's four or six number wheels from a pit mounted or remote location. AMCO's encoder features an optional fully potted glass lens for pit settings, permanently sealed to eliminate any chance of moisture penetration. The AMCO Encoder features a programmable ID; leak detector that provides visual indication of plumbing leaks; factory potted reading pads for wall or pit-lid mounting; and low power voltage for Electronic and Automatic Meter Reading (AMR) applications.

Automatic Meter Reading (AMR). AMCO Water offers the full spectrum of RF technology alternatives - Walk-by, Drive-by and Fixed Network, to reduce reading cost beyond electronic meter reading, while further increasing personnel safety. RF Transmitters accept input from the AMCO Encoder or AMCO Digital Register for reliable measurement inputs. RF Systems from AMCO are designed for reading both pit and inside set meter installations, and are to perform in the extremes of service conditions they will encounter.

Dimensions and Net Weights

Meter Size	Dimension (inches)					Weight (lbs.)
	A	B	C	D	E	
5/8" x 1/2"	7 1/2	5 3/8	1 3/8	4 3/4	9 3/8	3 1/4
5/8" x 3/4"	7 1/2	5 3/8	1 3/8	4 3/4	9 3/8	3 1/4
3/4" x 3/4"	9	5 15/16	1 15/16	5	9 15/16	3 5/8
3/4" x 1"	9	5 15/16	1 15/16	5	9 15/16	4

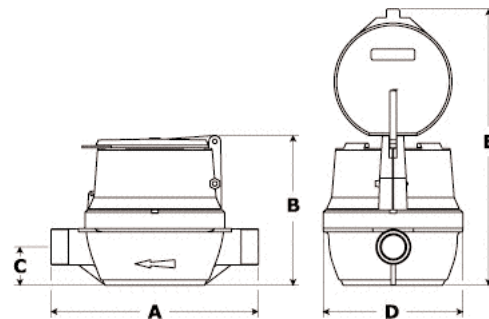

TORX® is a registered trademark of Camcar Division of Textron, Inc.
 InsideR™ is a trademark of AMCO Water Metering Systems.

The company's policy is one of continuous product improvement and the right is reserved to modify the specifications contained herein without notice. These products have been manufactured with current technology and in accordance with applicable AWWA Standards.

© 2003 AMCO Water Metering Systems Inc. All rights reserved.

Caribbean
 AMCO Water Metering Systems
 P. O. Box 225
 Carretera 112 KM 2.3
 Isabela, PR 00662
 787-872-2006
 FAX 787-872-5427
 e-mail:
 prwatermeters@amcowater.com

Mexico
 Elster Medidores
 Lago Omega #281
 Col. Modelo Pensil.
 Del. Miguel Hidalgo
 C P 11460
 525 55 203 8002
 FAX 525 55 203 8270
 e-mail:
 amcowater@prodigy.net.mx

C700-POLY-5834/01-03